

# FT17H

## Features

- The best and long selling FT17H is the hallmark of FOSTEX horn tweeter.
- The brisk high frequency sound and high efficiency are brought by the combination of the aluminum horn/equalizer and the strong magnetic circuit.
- The shielded type magnetic circuit is enough for comfortable use with TV sets or AV systems.



## Specifications

### &

### Thiele/Small Parameters

Impedance	: 8	Ω
Reproduction Frequency Response	: 5 kHz - 40 kHz	
S.P.L.	: 98.5	dB/W(m)
Power Handling	: 30	W (music)
Cutoff Frequency	: 2.6	kHz
Recommended Crossover Frequency	: 5	kHz or more
Magnet Weight	113.5	g / 0.25 lb
Net Weight	340	g / 0.75 lb

## Frequency Response / Impedance

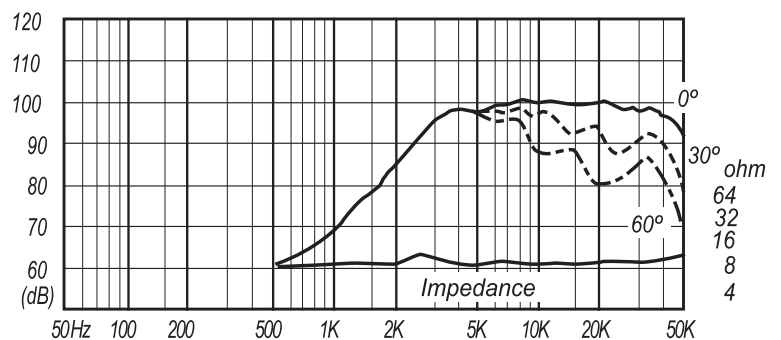

## Configuration Example

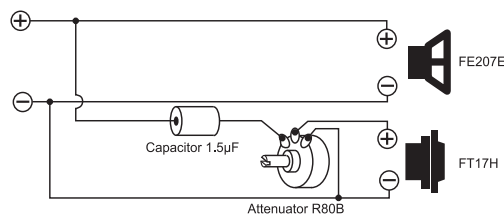

## Dimensions & Mounting Information

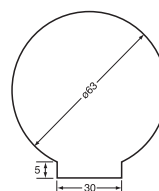
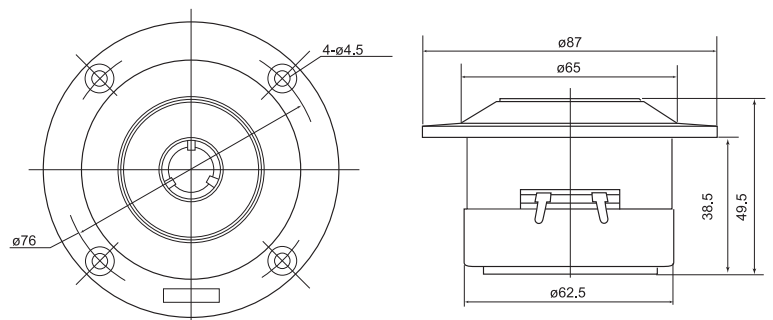

Overall Diameter	: 87	mm / 3.5	in
Baffle Hole Diameter	: 65	mm / 2.6	in
Depth	: 49.5	mm / 1.9	in